

Karlsruhe Institute of Technology

Reliable Computing I

Lecture 5: Reliability Evaluation

Instructor: Mehdi Tahoori

INSTITUTE OF COMPUTER ENGINEERING (ITEC) – CHAIR FOR DEPENDABLE NANO COMPUTING (CDNC)



KIT – University of the State of Baden-Wuerttemberg and
National Research Center of the Helmholtz Association

www.kit.edu

Today's Lecture

Karlsruhe Institute of Technology

- Reliability evaluation
 - Permanent and temporary failures
- Combinatorial modeling
 - Series
 - Parallel
 - Series-parallel
 - Non-series-parallel
 - k-out-of-n
 - TMR vs. Simplex
 - Effects of voter, coverage

(c) 2016, Mehdi Tahoori

Reliable Computing I: Lecture 5

2

Evaluation Criteria



- A method of evaluation is required in order to compare the redundancy techniques and make subsequent design tradeoffs
- Modeling techniques are very vital means for obtaining reasonable predictions for system reliability and availability
 - Combinatorial: series/parallel, K-of-N, nonseries/nonparallel
 - Markov: time invariant, discrete time, continuous time, hybrid
 - Queuing
- Using these techniques probabilistic models of systems can be created and used to evaluate system reliability and/or availability

Basic Reliability Measures



- Reliability: durational (default)
 - $R(t) = P\{\text{correct operation in duration } (0, t)\}$
- Availability: instantaneous
 - $A(t) = P\{\text{correct operation at instant } t\}$
 - Applied in presence of temporary failures
 - A steady-state value is the expected value over a range of time.
- Transaction Reliability: single transaction
 - $R_t = P\{\text{a transaction is performed correctly}\}$

Mean time to ...



- Mean Time to Failure (MTTF):
 - expected time the unit will work without a failure.
- Mean time between failures (MTBF):
 - expected time between two successive failures.
 - Applicable when faults are temporary.
 - The time between two successive failures includes repair time and then the time to next failure.
- Mean time to repair (MTTR):
 - expected time during which the unit is non-operational.

Failures with Repair



- Time between failures: time to repair + time to next failure

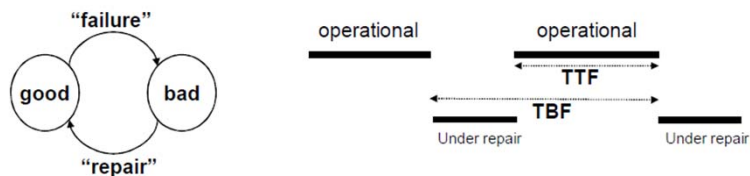

- $MTBF = MTTF + MTTR$
- MTBF, MTTF are same when $MTTR \approx 0$
- Steady state availability = $MTTF / (MTTF + MTTR)$

Mission Time (High-Reliability Systems)



- Reliability throughout the mission must remain above a threshold reliability R_{th} .
- Mission time T_M : defined as the duration in which $R(t) \geq R_{th}$.
- R_{th} may be chosen to be perhaps 0.95.
- Mission time is a strict measure, used only for very high reliability missions.

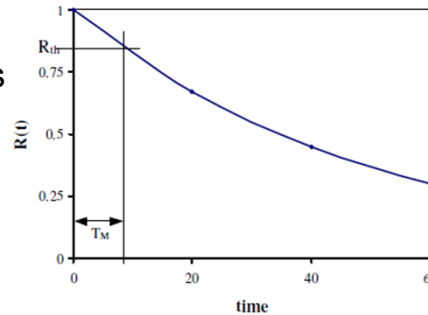

Two Basic cases



- We next consider two very important basic cases that serve as the basis for time-dependent analysis.
 1. Single unit subject to permanent failure
 - We will assume a constant failure rate to evaluate reliability and MTTF.
 2. Single unit with temporary failures
 - System has two states Good and Bad, and transitions among them are defined by transition rates.
- Both of these are example of Markov processes.

Single Unit with Permanent Failure



- Assumption: constant failure-rate λ
- Reliability = $R(t) = e^{-\lambda t}$
- $MTTF = \int_0^{\infty} R(t) dt = \int_0^{\infty} e^{-\lambda t} dt = \frac{1}{\lambda}$

- **Ex 1:** a unit has MTTF = 30,000 hrs. Find failure rate.
 $\lambda = 1/30,000 = 3.33 \times 10^{-5} / \text{hr}$
- **Ex 2:** Compute mission time T_M if $R_{th} = 0.95$.
 $e^{-\lambda T_M} = 0.95 \quad T_M = -\ln(0.95) / \lambda \approx 0.051 / \lambda$
- **Ex 3:** Assume $\lambda = 3.33 \times 10^{-5}$, and $R_{th} = 0.95$ find T_M .
 Ans: $T_M = 1538.8$ hrs
 (compare with MTTF = 30,000)

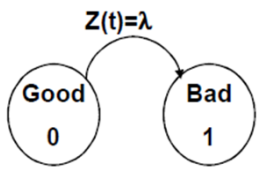

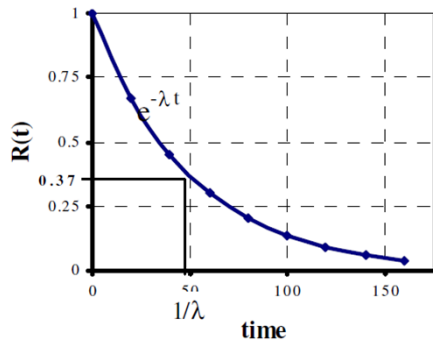

(c) 2016, Mehdi Tahoori Reliable Computing I: Lecture 5 9

Single Unit: Temporary Failures



- Temporary: intermittent, transient, permanent with repair



- $p_0(t) = p_0(0)e^{-(\lambda+\mu)t} + \frac{\mu}{\lambda+\mu}(1 - e^{-(\lambda+\mu)t})$
- $p_1(t) = 1 - p_0(t)$
- Availability $A(t) = p_0(t)$
- Steady-state availability ($t \rightarrow \infty$) $A(t) = \frac{\mu}{\lambda+\mu}$
- Reliability: $R(t) = P\{\text{no failure in } (0,t)\} = e^{-\lambda t}$
- $MTTF = \frac{1}{\lambda}$
- Same as permanent failure

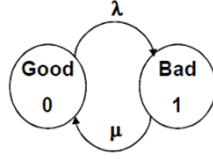

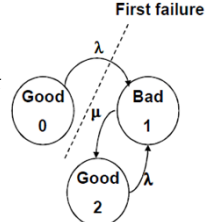

(c) 2016, Mehdi Tahoori Reliable Computing I: Lecture 5 10

Combinatorial Modeling



- System is divided into non-overlapping modules
- Each module is assigned either a probability of working, P_i , or a probability as function of time, $R_i(t)$
- The goal is to derive the probability, P_{sys} , or function $R_{\text{sys}}(t)$ of correct system operation
- Assumptions:
 - module failures are independent
 - once a module has failed, it is always assumed to yield incorrect results
 - system is considered failed if it does not satisfy minimal set of functioning modules
 - once system enters a failed state, other failures cannot return system to functional state
- Models typically enumerate all the states of the system that meet or exceed the requirements of correctly functioning system

Combinatorial Reliability



- Objective is: Given a
 - systems structure in terms of its units
 - reliability attributes of the units
 - some simplifying assumptions
- We need to evaluate the overall reliability measure.
- There are two extreme cases we will examine first:
 - Series configuration
 - Parallel configuration
 - Other cases involve combinations and other configurations.
- Note that conceptual modeling is applicable to $R(t)$, $A(t)$, $R_t(t)$. A system is either good or bad.

Series configuration



- Assume system has n components, e.g. CPU, memory, disk, terminal
- All components should survive for the system to operate correctly

$$\begin{aligned} R_S &= P\{U_1 \text{ good} \cap U_2 \text{ good} \cap U_3 \text{ good}\} \\ &= P\{U_1 g\}P\{U_2 g\}P\{U_3 g\} \\ &= R_1 R_2 R_3 \end{aligned}$$

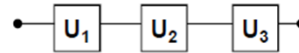

- Reliability of the system

$$R_{series}(t) = \prod_{i=1}^n R_i(t) \text{ where } R_i(t) \text{ is the reliability of module } i$$

Series configuration



- For exponential failure rate of each component

$$\text{If } R_i(t) = e^{-\lambda_i t}$$

$$\text{then } R_s(t) = \prod e^{-\lambda_i t} = e^{-[\lambda_1 + \lambda_2 + \dots + \lambda_n]t}$$

$$R_{series}(t) = e^{-\sum_{i=1}^n \lambda_i t} = e^{-\lambda_{system} t}$$

Where $\lambda_{system} = \sum_{i=1}^n \lambda_i$ corresponds to the failure rate of the system

- System failure rate is the sum of individual failure rates:

$$\lambda_s = \lambda_1 + \lambda_2 + \dots + \lambda_n$$

- Mean time to failure:

$$MTTF_{series} = \frac{1}{\sum_{i=1}^n \lambda_i}$$

“A chain is as strong as it's weakest link”?

- Let us see for a 4-unit series system
 - Assume $R_1=R_2=R_3=0.95$, $R_4=0.75$
 - $R_s=0.643$
- Thus a chain is slightly weaker than its weakest link!
- The plot gives reliability of a 10-unit system vs a single system. Each of the 10 units are identical.
 - More units, less reliability

if $X_i \equiv$ lifetime of component i then

$$0 \leq E[X] \leq \min \{E[X_i]\}$$

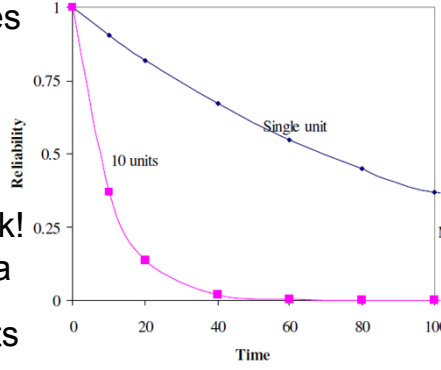



(c) 2016, Mehdi Tahoori
Reliable Computing I: Lecture 5
15

Parallel Systems

- Assume system with spares
- As soon as fault occurs a faulty component is replaced by a spare
- Only one component needs to survive for the system to operate correctly
- Prob. of module i to survive = R_i
- Prob. of module i not to survive = $(1 - R_i)$
- Prob. of no modules to survive =
 - $(1 - R_1)(1 - R_2) \dots (1 - R_n)$
- Prob [at least one module survives] =
 - $1 - \text{Prob [none module survives]}$
- Reliability of the parallel system

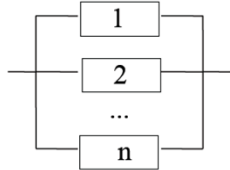
$$R_{parallel}(t) = 1.0 - \prod_{i=1}^n (1.0 - R_i(t))$$

(c) 2016, Mehdi Tahoori
Reliable Computing I: Lecture 5
16

Parallel Systems



$$\begin{aligned}
 E(X) &= \int_0^{\infty} [1 - (1 - e^{-\lambda t})^n] dt \\
 &= \dots \\
 &= \frac{1}{\lambda} \sum_{i=1}^n \frac{1}{i} \\
 &\approx \frac{\ln(n)}{\lambda}
 \end{aligned}$$

Parallel Configuration: Example



- Problem: Need system reliability $R_s = 1 - \epsilon$
 - How many parallel units are needed
 - If $R_1 = R_2 = \dots = R_m$, $R_m < R_s$

- Solution : $1 - R_s = (1 - R_m)^x$

$$\epsilon = (1 - R_m)^x$$

$$x = \frac{\ln \epsilon}{\ln(1 - R_m)}$$

Assume $R_s = 0.9999$ ($\epsilon = 0.0001$),
 $R_m = 0.9$
 gives $x = 4$.

Series-Parallel Systems



- Consider combinations of series and parallel systems
- Example, two CPUs connected to two memories in different ways

$$R_{\text{sys}} = 1 - (1 - R_a R_b) (1 - R_c R_d)$$

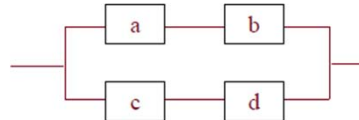

$$R_{\text{sys}} = (1 - (1 - R_a)(1 - R_c)) (1 - (1 - R_b)(1 - R_d))$$

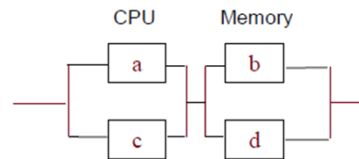

Non-Series-Parallel-Systems



- Often a “success” diagram is used to represent the operational modes of the system

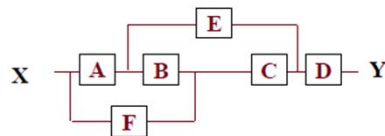

Each path from X to Y represents a configuration that leaves the system operational

- Reliability of the system can be derived by expanding around a single module m
- $R_{\text{sys}} = R_m P(\text{system works} \mid m \text{ works}) + (1 - R_m) P(\text{system works} \mid m \text{ fails})$
 - where the notation $P(s \mid m)$ denotes the conditional probability “s given m has occurred”

Non-Series-Parallel-Systems

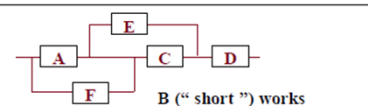

B ("short") works

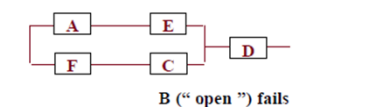

B ("open") fails

Reduced model with B replaced

$$R_{sys} = R_B P(\text{system works} | B \text{ works}) + (1 - R_B) \{R_D [1 - (1 - R_A R_E)(1 - R_F R_C)]\}$$

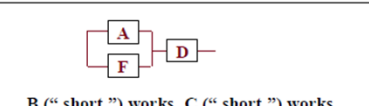

B ("short") works, C ("short") works

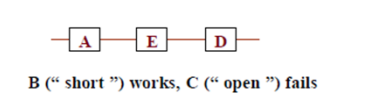

B ("short") works, C ("open") fails

Reduction with B and C replaced

$$P(\text{system works} | B \text{ works}) = R_C \{R_D [1 - (1 - R_A)(1 - R_E)]\} + (1 - R_C)(R_A R_D R_E)$$

Letting $R_A \dots R_F = R_m$ yields $R_{sys} = R_m^6 - 3R_m^5 + R_m^4 + 2R_m^3$

(c) 2016, Mehdi Tahoori
Reliable Computing I: Lecture 5
21

Non-Series-Parallel-Systems

- For complex success diagrams, an upper-limit approximation on R_{sys} can be used
- An upper bound on system reliability is:

$$R_{sys} \leq 1 - \prod (1 - R_{path\ i})$$

$R_{path\ i}$ is the serial reliability of path i

- The above equation is an upper bound because the paths are not independent.
- That is, the failure of a single module affects more than one path.



(c) 2016, Mehdi Tahoori
Reliable Computing I: Lecture 5
22

Non-Series-Parallel-Systems

■ Example

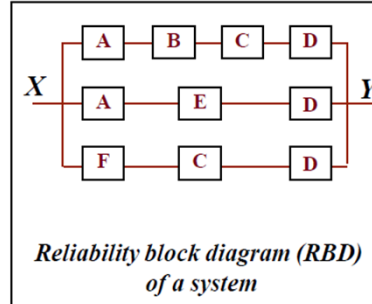

$$R_{\text{sys}} \leq 1 - (1 - R_A R_B R_C R_D)(1 - R_A R_E R_D)(1 - R_F R_C R_D)$$

$$R_{\text{sys}} \leq 2R_m^3 + R_m^4 - R_m^6 - 2R_m^7 + R_m^{10}$$

k-out-of-n Systems

■ Assumption:

- we have n identical modules with statistically independent failures.

■ k-out-of-n system is operational if

- k of the n modules are good.

■ System reliability then is $R_{k/n} = \sum_{i=k}^n \binom{n}{i} p^i (1-p)^{n-i}$

- Where p is the probability that one unit is good
- $R_{k/n}$ is the summations of the probabilities of all good combinations
- $\binom{n}{i} = \frac{n!}{i!(n-i)!}$: choose i good systems out of n

Triple Modular Redundancy



2-out-of-3 system

$$\begin{aligned}
 R_{TMR} &= \sum_{i=2}^3 \binom{3}{i} R^i (1-R)^{3-i} \\
 &= 3R^2(1-R) + R^3 \\
 &= 3R^2 - 2R^3
 \end{aligned}$$

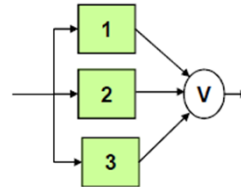

- Where R is the reliability of a single module.
- This assumes that the voter is perfect
 - a reasonable assumption if the voter complexity is much less than an individual module.

TMR vs. Simplex



System reliability vs. module reliability

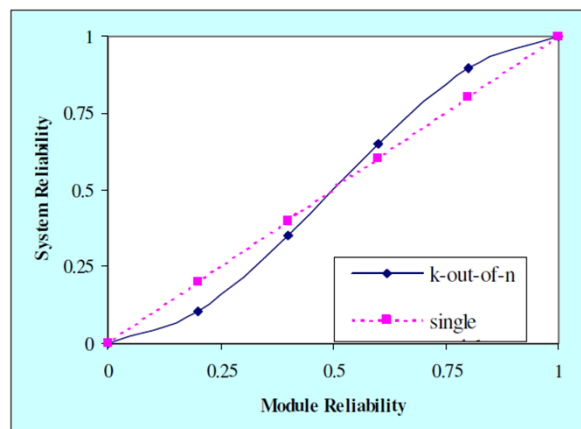

- What is the conclusion?

TMR vs. Simplex: MTTF



- Compare reliability of simplex and TMR systems

$$R_{\text{simplex}}(t) = e^{-\lambda t}$$

$$MTTF_{\text{simplex}} = \int e^{-\lambda t} dt = 1/\lambda$$

$$MTTF = \int_0^{\infty} R_{TMR}(t) dt$$

$$R_{TMR}(t) = e^{-3\lambda t} + \binom{3}{2} e^{-2\lambda t} (1 - e^{-\lambda t})$$

$$= \int_0^{\infty} (3e^{-2\lambda t} - 2e^{-3\lambda t}) dt$$

$$MTTF_{TMR} = \frac{3}{2\lambda} - \frac{2}{3\lambda} = \frac{5}{6\lambda}$$

$$MTTF_{\text{simplex}} > MTTF_{TMR}$$

TMR vs. Simplex: MTTF

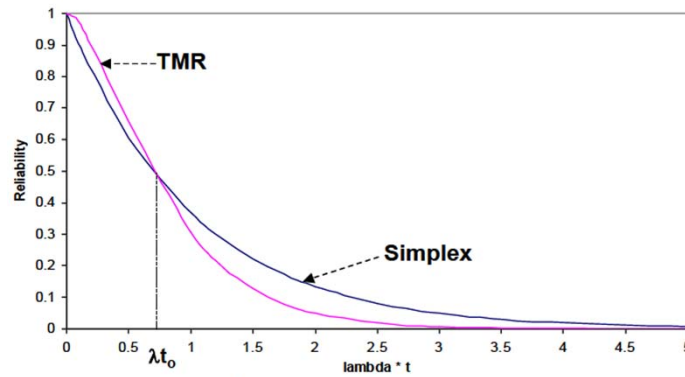

$$R_{TMR}(t) \geq R(t) \quad 0 \leq t \leq t_0$$

$$R_{TMR}(t) \leq R(t) \quad t_0 \leq t < \infty$$

$$\text{where } t_0 = \frac{\ln 2}{\lambda} \approx \frac{0.7}{\lambda}$$

TMR vs. Simplex: Mission Time



- Mission time

$$R_{Th} = 3e^{-2\lambda t_m} - 2e^{-3\lambda t_m}$$

- A numerical solution for t_m can be obtained iteratively

- *Ex*: $\lambda = 1/\text{year}$, $R_{Th} = 0.95$

	MTTF	t_m
single	1yr	0.05
TMR	0.83	0.145

- Thus TMR mission time is much better.

TMR vs. Simplex: Availability



- Temporary faults: steady state

$$A_{TMR} = 3A^2 - 2A^3, A = \frac{\mu}{\lambda + \mu}$$

$$\text{EX: } \frac{\lambda}{\mu} = 0.01 \Rightarrow A = 0.9901$$

$$\Rightarrow \bar{A} = 0.01$$

$$A_{TMR} = 0.9997 \Rightarrow \bar{A}_{TMR} = 0.0003$$

- Thus TMR can greatly reduce down-time in presence of temporary faults

TMR vs. Simplex: Summary



- Instead of MTTF, look at mission time
- Reliability of K-out-of-N systems very high in the beginning
 - spare components tolerate failures
- Reliability sharply falls down at the end
 - system exhausted redundancy, more hardware can possibly fail
- Such systems useful in aircraft control
 - very high reliability, short time
 - 0.99999 over 10 hour period

System with Backup: Effect of Coverage



- Failure detection is not perfect
 - Reconfiguration may not succeed
 - Attach a coverage “c”

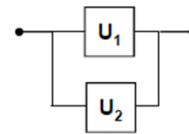

$$\begin{aligned}
 R_s &= P\{U_1 \text{ good}\} + \\
 &\quad P\{U_2 \text{ has taken over} \mid U_1 \text{ failed}\}P\{U_1 \text{ failed}\} \\
 &= R_1 + R_2C(1 - R_1)
 \end{aligned}$$

where $C = P\{\text{failure detected and successful switchover}\}$

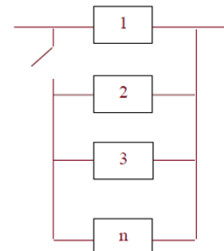

- General case, n-1 spares

$$R_s = R_m \sum_{i=0}^{n-1} C^i (1 - R_m)^i$$

System with Backup: Effect of Coverage



- If coverage is 100%, then given low module reliability, can increase system reliability arbitrarily
 - With low coverage, reliability saturates

	R _m = 0.9	R _m = 0.7	R _m = 0.5
C=0.99, n=2	0.989	0.908	0.748
C=0.99, n=4	0.999	0.988	0.931
C=0.99, n=inf	0.999	0.996	0.990
C= 0.8 , n=2	0.972	0.868	0.700
C= 0.8 , n=4	0.978	0.918	0.812
C=0.8, n=inf	0.978	0.921	0.833

Effect of Voter



- Previous expression for reliability assumed voter 100% reliable
- Assume voter reliability R_v

$$R_{TMRV} = R_v (R_m^3 + \binom{3}{2} R_m^2 (1 - R_m))$$

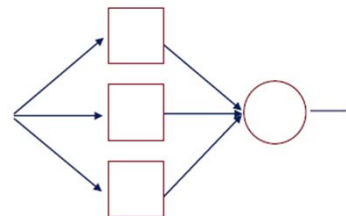

TMR+Spares



- TMR core, n-3 spares (assume same failure rate)
- System failure when all but one modules have failed.
 - If we start with 3 in the core and 2 spares, the sequence is:
 - 3+2 → 3+1 → 3+0 → 2+0 → failure
- Reliability of the system then is

$$R_s = R_{sw} [1 - nR(1-R)^{n-1} - (1-R)^n]$$
 - Where R is reliability of a single module and R_{sw} is the reliability of the switching circuit overhead.
 - R_{sw} should depend on total number of modules n, and relative complexity of the switching logic.
- Let us assume that $R_{sw} = (R^a)^n$,
 - where a is measure of relative complexity, generally a $\ll 1$
- $R_s = R^{an} [1 - nR(1-R)^{n-1} - (1-R)^n]$